

SMA6L

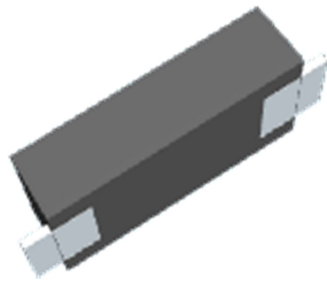

SMA6L

1: Certification

- System:
 - IATF 16949
 - ISO9001
 - ISO14001
 - ISO45001
- ROHS/REACH/ELV:
 - Lead frame、Solder、Molding compound、Post plating.
- UL 94: V-0
- MSL : level 1
- **AEC-Q101 (Rev E): Qualified Available**
- Whisker Test: JESD 201 class 2
- Solder bath temperature : 260°C maximum, 10 s

2: Internal Structure Diagram

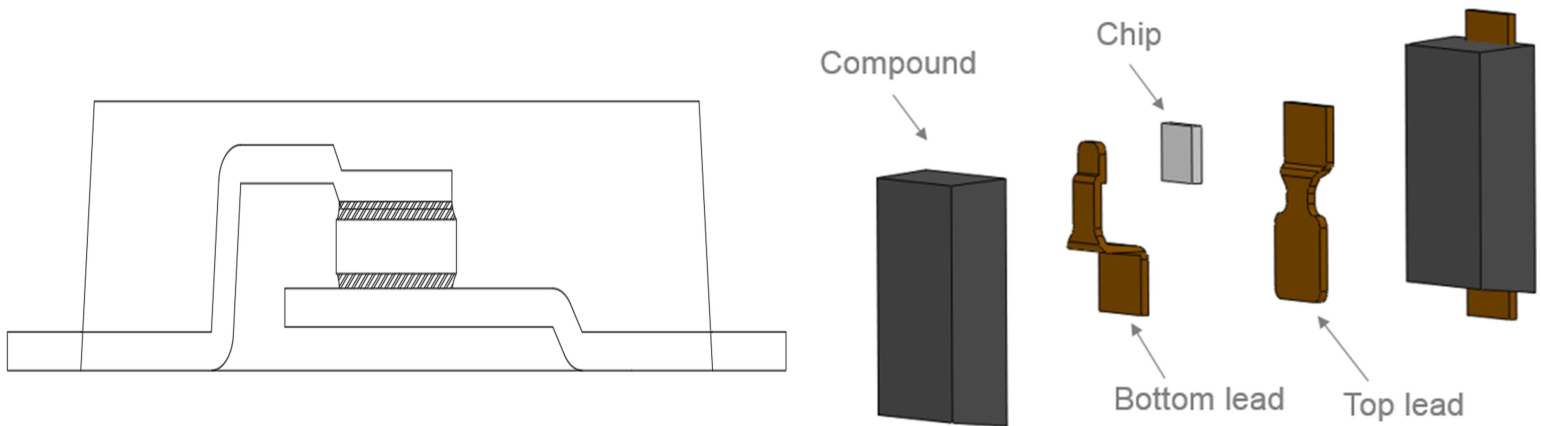

Meet Die Size

	Lead Pad(mm)	Die size(mil)	Wafer thickness (um)
Max	0.96	72.00	350.00
Min	0.35	32.00	150.00

3: Production line advantage

- 100% AOI in TMTT.
- Automated production line for all process.

4: Reliability Experiment

Test	Test Condition
HAST	80%VR/130°C/85%R.H.
Temp. Cycling	1000 cycles form -55°to 150°C
UHAST	96 hours at Ta = 130°C, RH = 85%
HTRB	1000 hours 150°
RSH	260°C , 10 s

5: Package Outline Dimensions in millimeters

5.1 POD

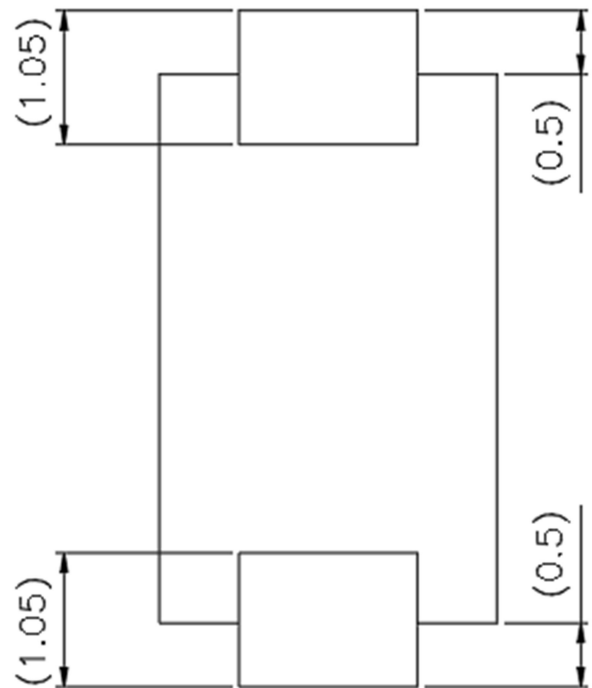
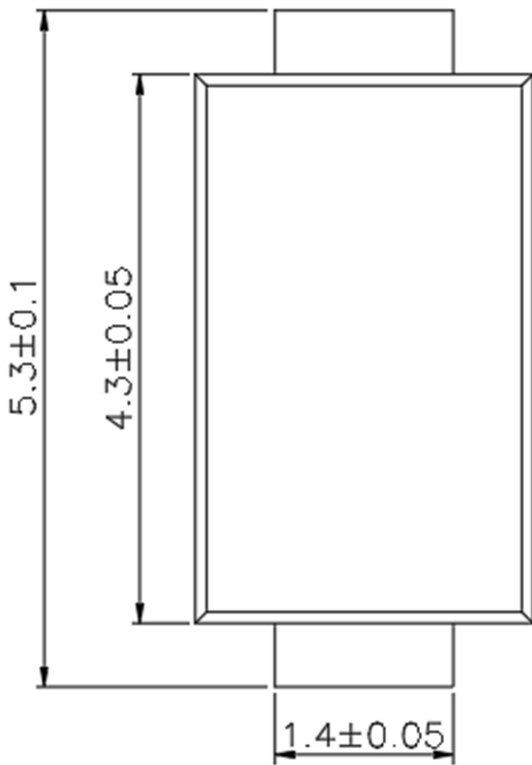
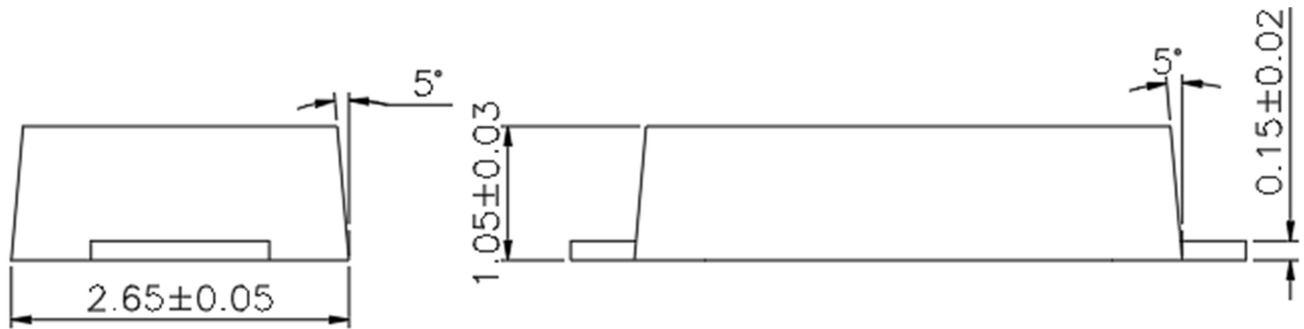

5.2 Package (tape & carrier) Dimensions in millimeters

